

# HIGH EFFICIENCY PLUG FANS WALL MOUNTED / FLOOR MOUNTED

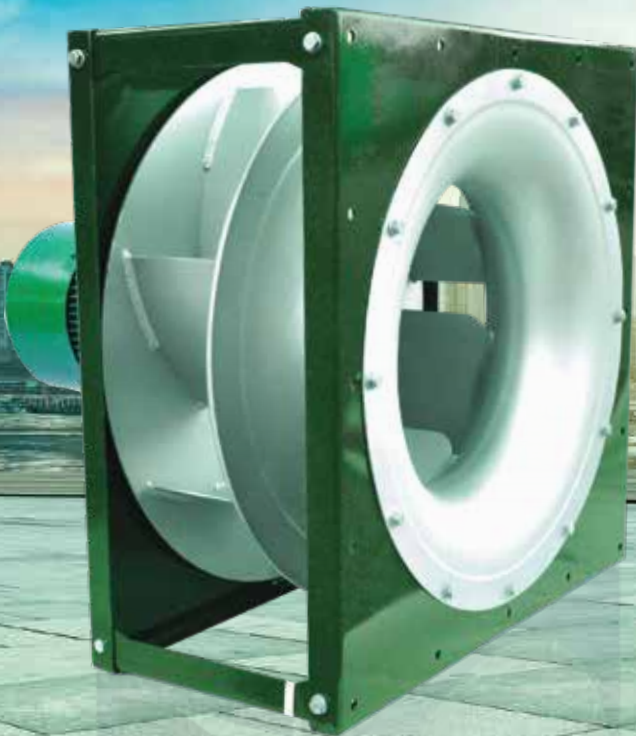

## WALL MOUNTED



## FLOOR MOUNTED

### IE5 CLASS ULTRA PREMIUM EFFICIENCY PERMANENT MAGNET MOTOR WITH INTEGRAL VFD

#### Application:

- HVAC
- Air handling units
- Clean room & labs
- Data centers (CRAH or AHUs)
- Refrigeration & Cooling Units

#### Industries / Sector:

- Automotive
- HVAC
- Automobile
- Food & beverages
- Pharmaceuticals
- Commercial refrigeration

[www.nadiairtechnics.com](http://www.nadiairtechnics.com)

# NADI HIGH EFFICIENCY PLUG FANS

## LIGHT WEIGHT WALL / FLOOR MOUNTED PLUG FAN DIA 460

FAN TYPE	WALL / FLOOR PEDESTAL MOUNTED PLUG FAN
FAN MODEL NAME	HEABP-460
IMPELLER DIAMETER	460 MM
IMPELLER MOC	ALUMINIUM
PLUG STRUCTURE MOC	CARBON STEEL
FLOW	4660 CMH / 8000 CMH
PRESSURE	43 MMWC / 180 MMWC
SPEED	1450 RPM / 2800 RPM
FAN BKW (MAX)	< 0.65 KW @ 1.2 KG/M
MOTOR INPUT POWER (MAX)	< 0.72 KW @ 1.2 KG/M
FAN STATIC EFFICIENCY	84% / 83% (SPECIFIC TO ABOVE AEROLIC DUTY)
MOTOR RATING	0.75 KW/ 5.5 KW
FREQUENCY	50 HZ
MOTOR TYPE (PERMANENT MAGNET)	IE5 ULTRA PREMIUM EFF. WITH INTEGRAL VFD
MOTOR BODY	DIE CAST ALUMINIUM
TYPE OF PROTECTION	IP 54
AMBIENT TEMPERATURE	50° C
WEIGHT OF WALL MOUNTED	~50 KG (SPECIFIC TO 1450 RPM)
WEIGHT FLOOR MOUNTED	~60 KG (SPECIFIC TO 1450 RPM)

## FLOOR MOUNTED PLUG FAN DIA 460

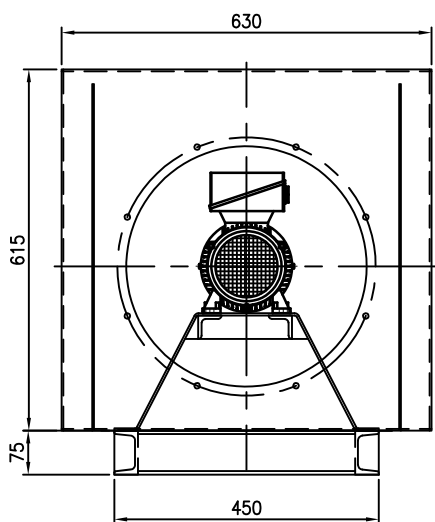

**ELEVATION**

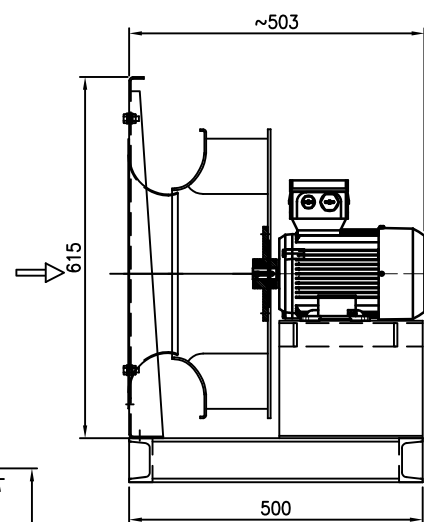
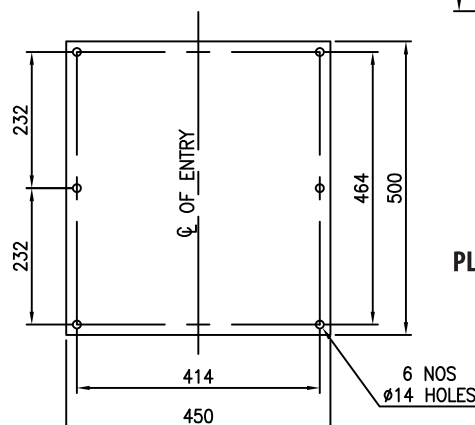

**END VIEW**

**PLAN FOUNDATION DETAIL (IN MM)**

# WALL MOUNTED PLUG FAN DIA 460

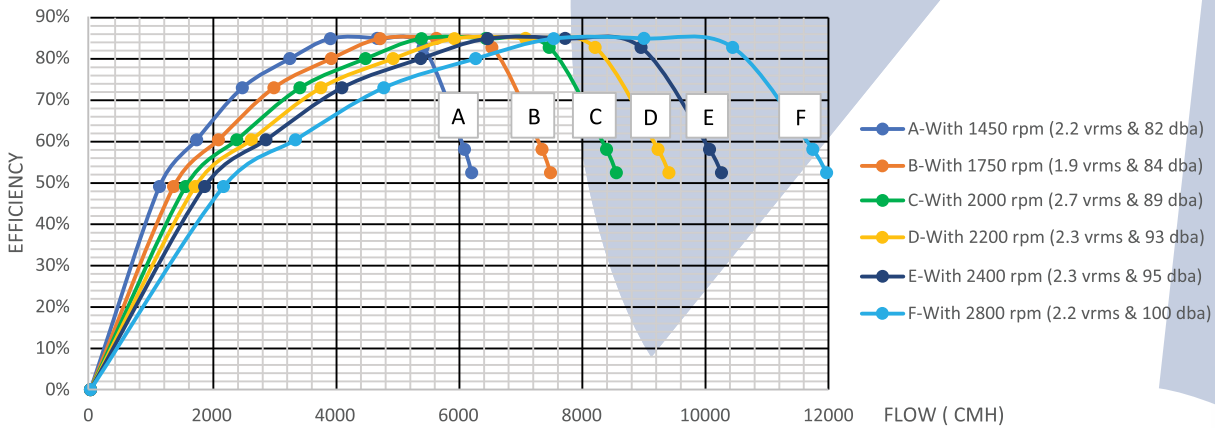
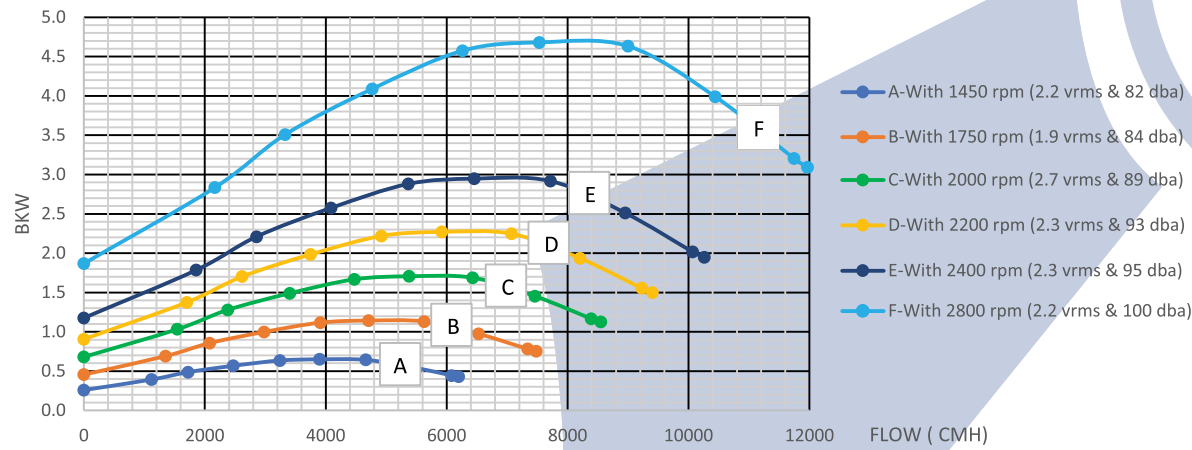
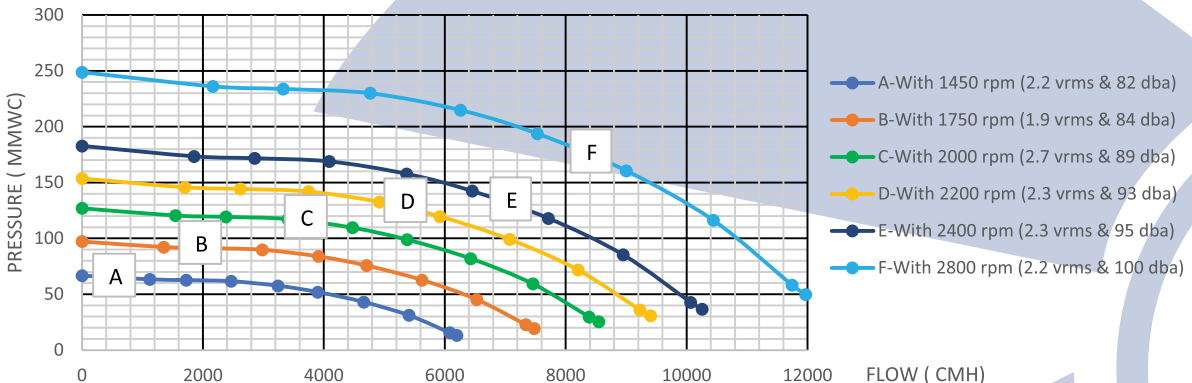
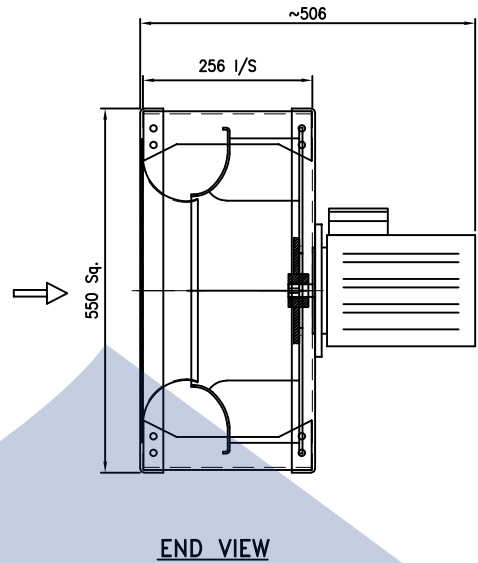
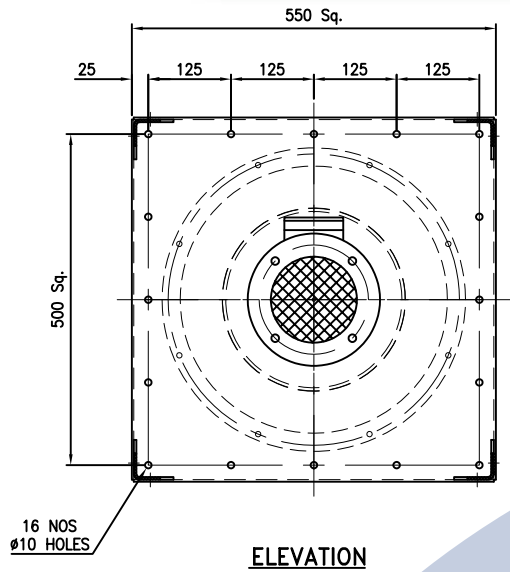

# NADI HIGH EFFICIENCY PLUG FANS

## LIGHT WEIGHT WALL / FLOOR MOUNTED PLUG FAN DIA 560

FAN TYPE	WALL / FLOOR PEDESTAL MOUNTED PLUG FAN
FAN MODEL NAME	HEABP-560
IMPELLER DIAMETER	560 MM
IMPELLER MOC	ALUMINIUM
PLUG STRUCTURE MOC	CARBON STEEL
FLOW	9400 CMH / 15000 CMH
PRESSURE @ 1.2 KG/M <sup>3</sup>	70 MMWC / 170 MMWC
SPEED	1450 RPM / 2200 RPM
FAN BKW (MAX) @ 1.2 KG/M <sup>3</sup>	< 2.30 KW / < 8.5 KW
MOTOR INPUT POWER (MAX) @ 1.2 KG/M <sup>3</sup>	< 2.8 KW / < 11 KW
FAN STATIC EFFICIENCY	82%/81% (SPECIFIC TO ABOVE AEROLIC DUTY)
MOTOR RATING	3.7 KW / 11 KW
FREQUENCY	50 HZ
MOTOR TYPE -(PERMANENT MAGNET)	IE5-ULTRA PREMIUM EFF.-INTEGRAL VFD
MOTOR BODY	DIE CAST ALUMINIUM
TYPE OF PROTECTION	IP 54
AMBIENT TEMPERATURE	50° C
WEIGHT OF WALL MOUNTED	~62 KG (SPECIFIC TO 1450 RPM)
WEIGHT FLOOR MOUNTED	~74 KG (SPECIFIC TO 1450 RPM)

## FLOOR MOUNTED PLUG FAN DIA 560

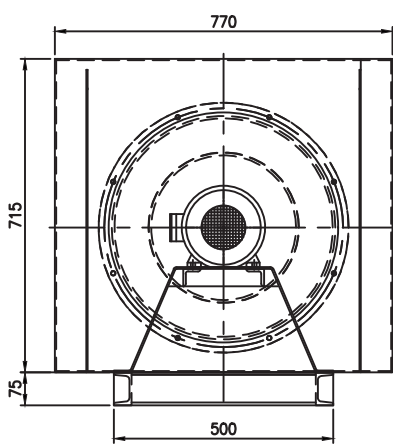

**ELEVATION**

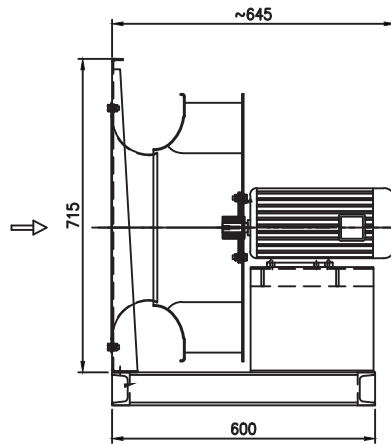

**END VIEW**

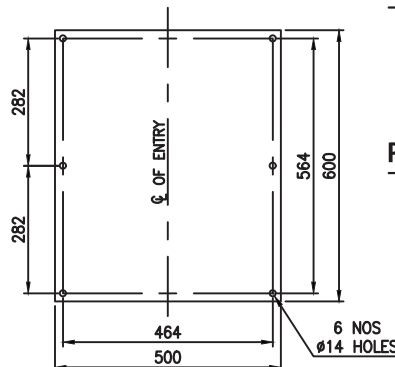

**PLAN FOUNDATION DETAIL (IN MM)**

# WALL MOUNTED PLUG FAN DIA 560

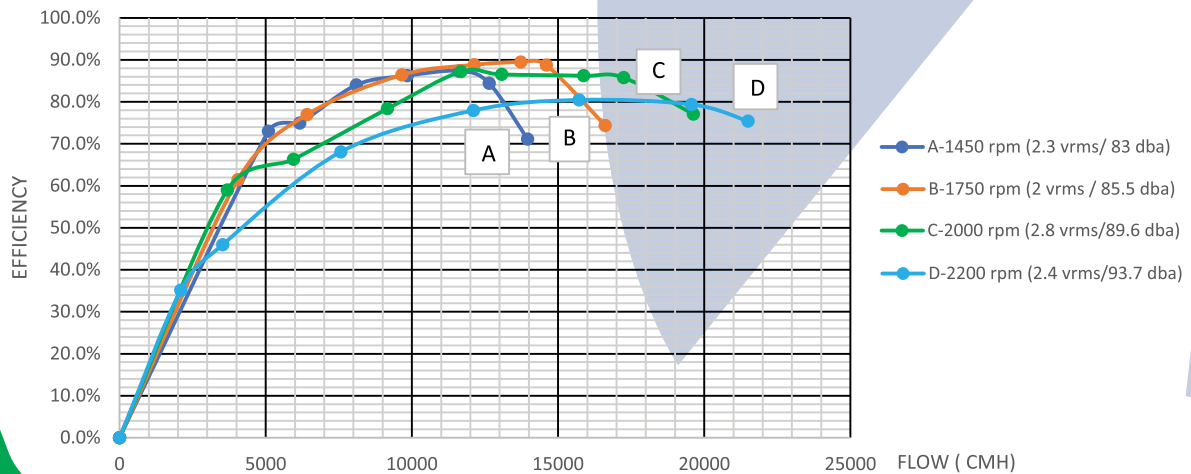
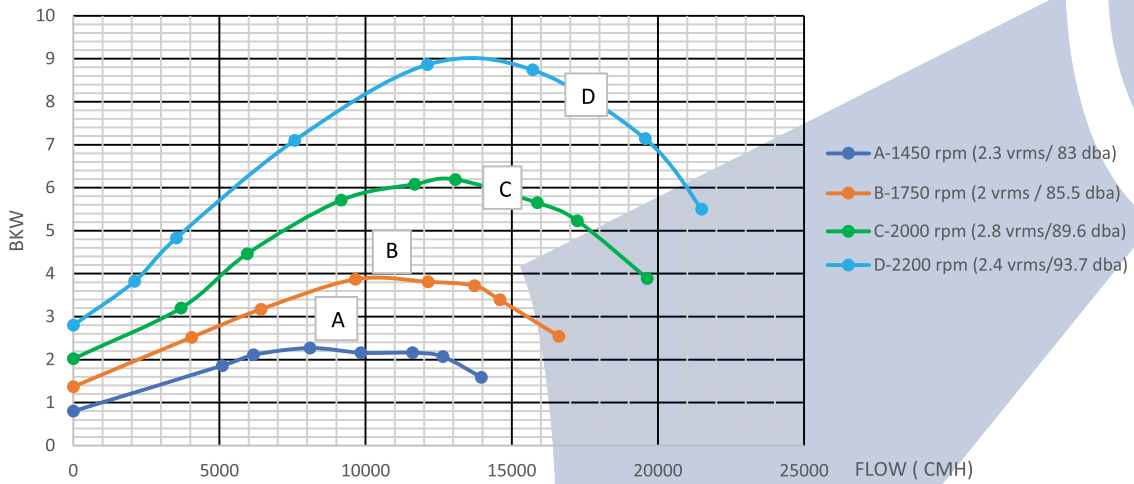
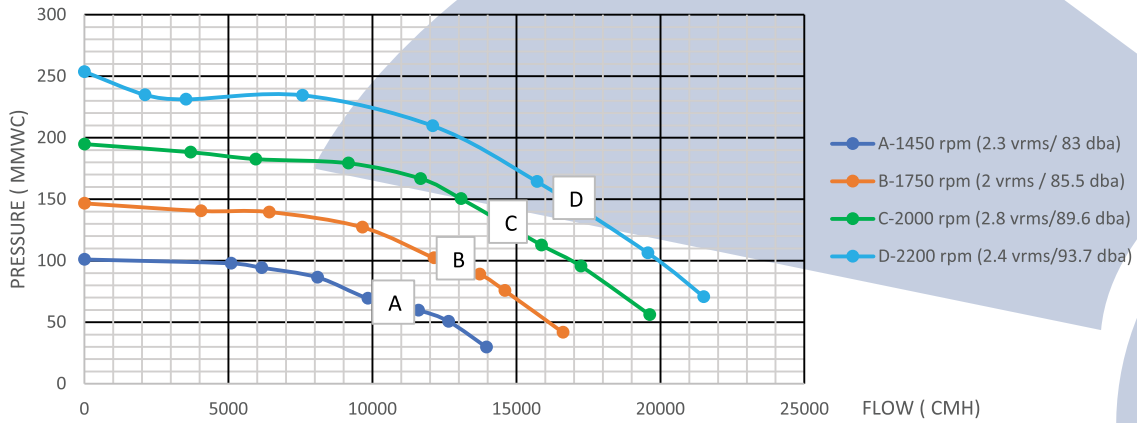
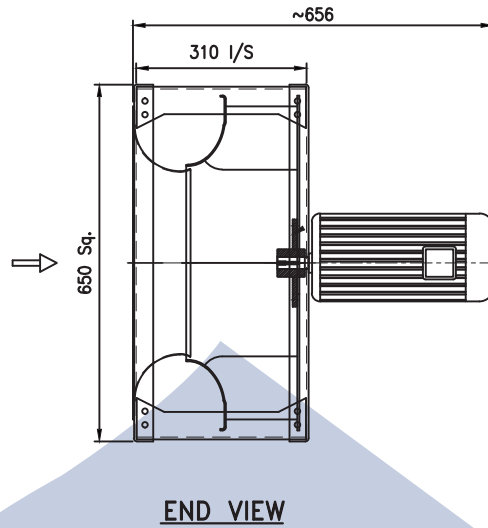
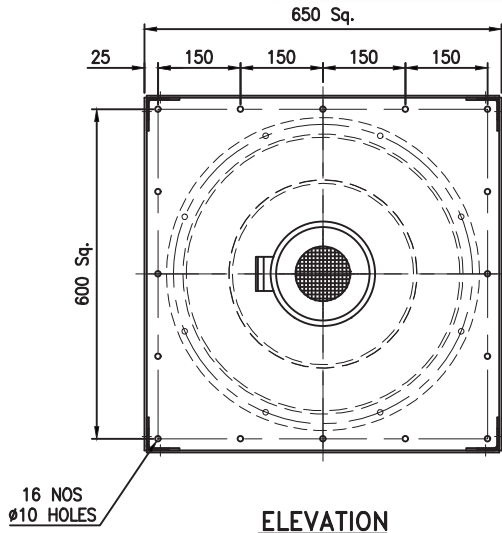

# NADI HIGH EFFICIENCY PLUG FANS

## LIGHT WEIGHT WALL / FLOOR MOUNTED PLUG FAN DIA 630

FAN TYPE	WALL / PEDESTAL MOUNTED PLUG FAN
FAN MODEL NAME	HEABP-630
IMPELLER DIAMETER	630 MM
IMPELLER MOC	ALUMINIUM
PLUG STRUCTURE MOC	CARBON STEEL
FLOW	19380 CMH / 24000 CMH
PRESSURE @ 1.2KG/M <sup>3</sup>	84MMWC / 250 MMWC
SPEED	1450 RPM / 2200 RPM
FAN BKW (MAX)@1.2 KG/M <sup>3</sup>	< 5.4 KW / < 20 KW
MOTOR INPUT POWER (MAX) @ 1.2 KG/M <sup>3</sup>	< 6 KW / < 21KW
FAN STATIC EFFICIENCY	82% / 81.6% (SPECIFIC TO ABOVE AEROLIC DUTY)
MOTOR RATING	7.5 KW/ 22 KW
FREQUENCY	50 HZ
MOTOR TYPE (PERMANENT MAGNET)	IE5 CLASS ULTRA PREMIUM EFF.WITH INTEGRAL VFD
MOTOR BODY	DIE CAST ALUMINIUM
TYPE OF PROTECTION	IP 54
AMBIENT TEMPERATURE	50° C
WEIGHT OF WALL MOUNTED	~93 KG (SPECIFIC TO 1450 RPM)
WEIGHT FLOOR MOUNTED	~113 KG (SPECIFIC TO 1450 RPM)

## FLOOR MOUNTED PLUG FAN DIA 630

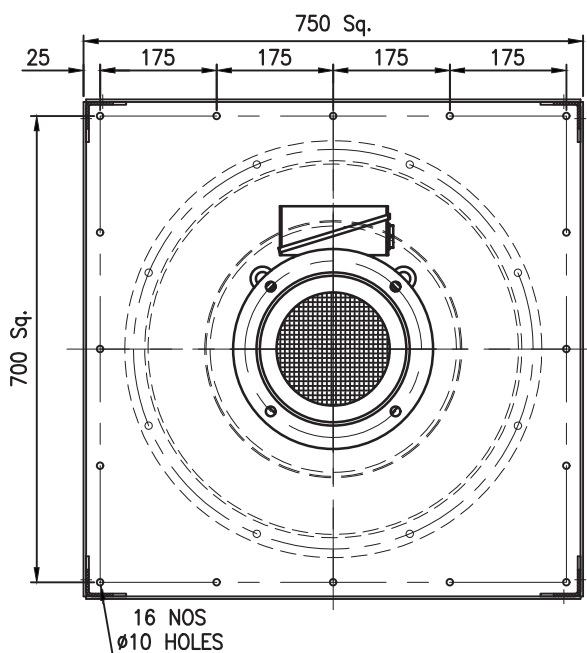

**ELEVATION**

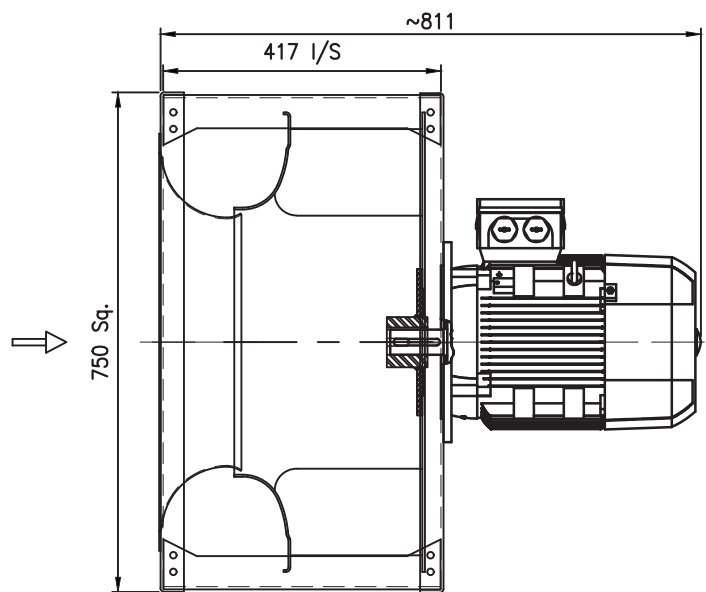

**END VIEW**

# WALL MOUNTED PLUG FAN DIA 630

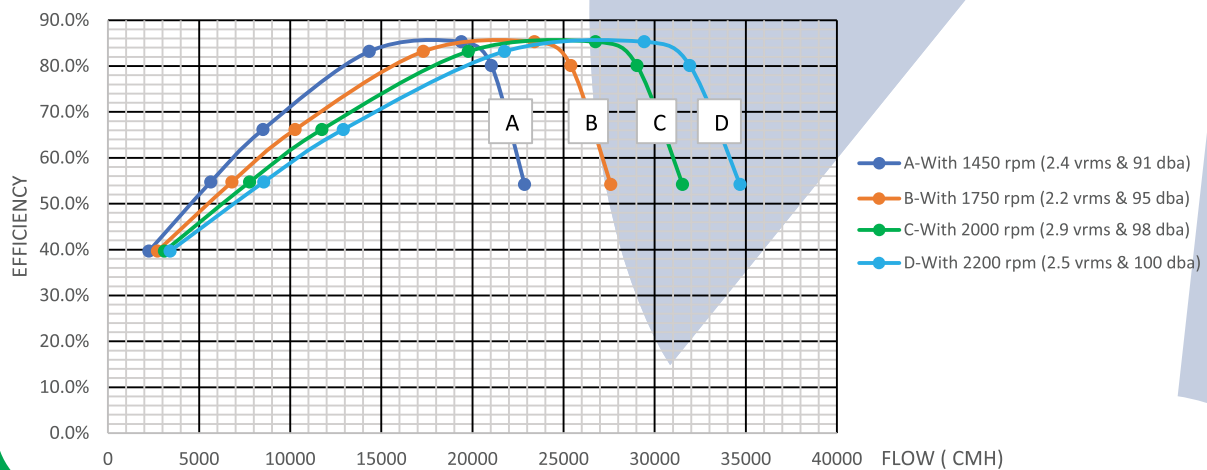
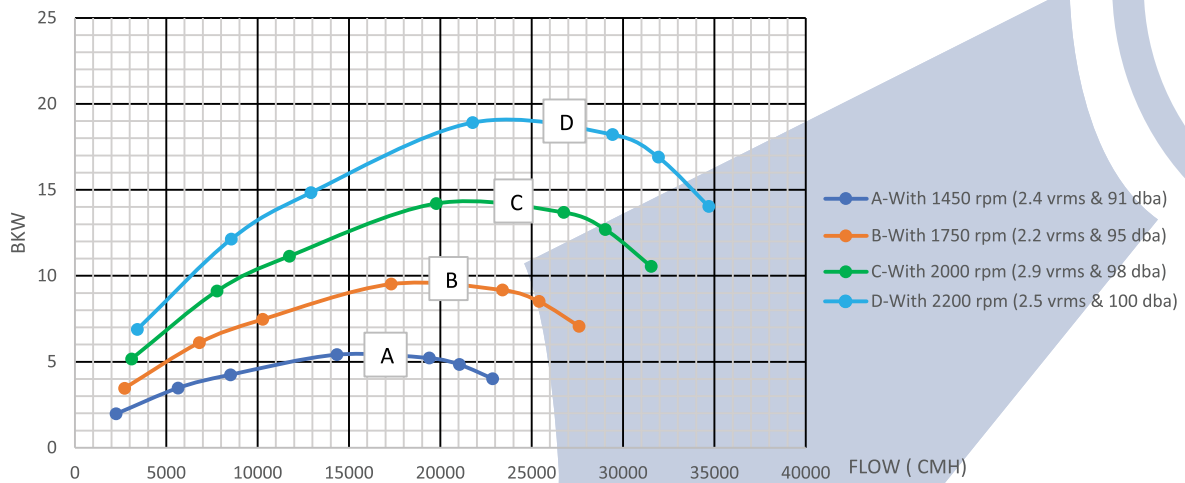
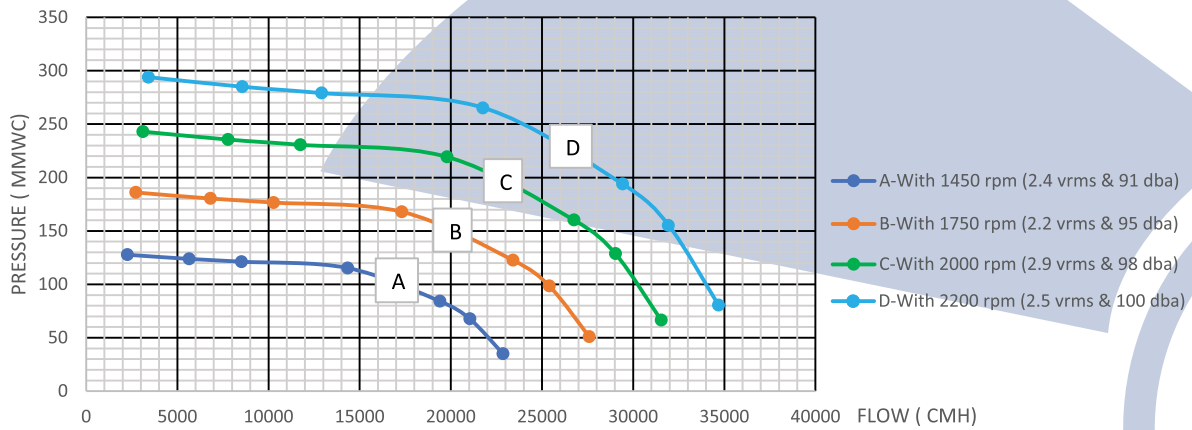
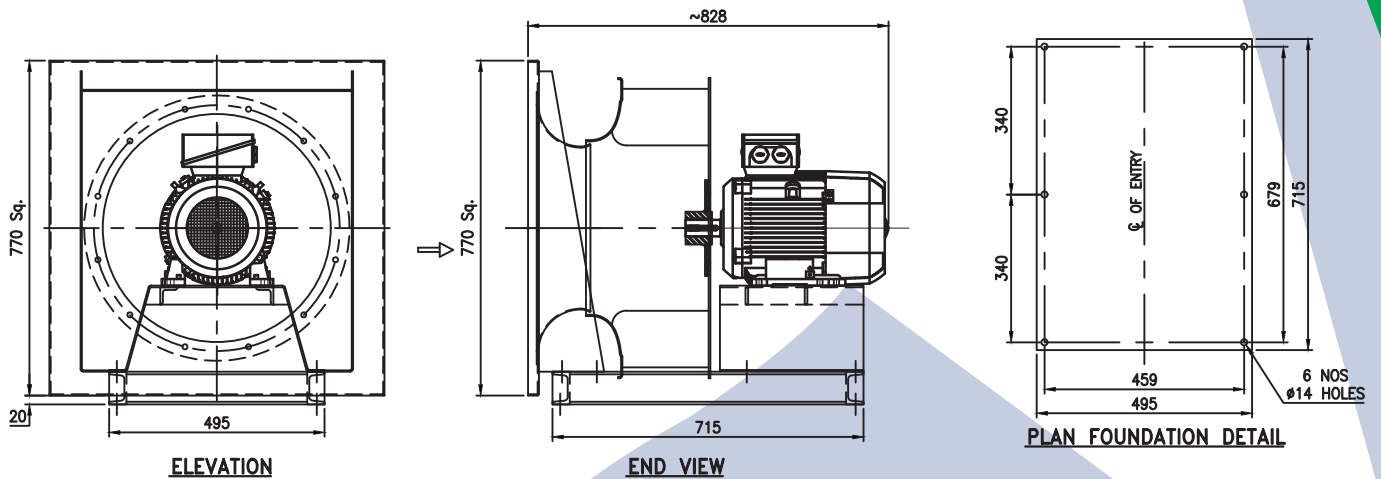



## **NADI Airtechnics Pvt. Ltd.**

Survey Nos. 9/11, 9/12, 114/1A GNT Road Azhinjivakkam,  
Jeganadhapuram Revenue Village, Ponneri Taluk, Thiruvallur  
District - 600 067, Tamil Nadu, India. Ph: +91 44 27984797 / 98 / 99  
Email: [info@nadiairtechnics.com](mailto:info@nadiairtechnics.com)

## **NADI Airtechnics U.S. LLC.**

180 KEHOE BLVD, CAROL STREAM, IL 60188, USA  
Ph: +1 (908) 656-3358 | Email: [nadius@nadiairtechnics.com](mailto:nadius@nadiairtechnics.com)

### **NADI ADVANTAGE ON-THE-GO!**

Buying a NADI product is just a click away.  
New Fan Requirement | Retrofit | Spares | After Sales & Service



 Scan To Download  
From App Store



 Scan To Download  
From Play Store

Website : [www.nadiairtechnics.com](http://www.nadiairtechnics.com)